

2015 RULES AND REGULATIONS

GENERAL RULES & GENERAL SAFETY RULES



Saskatoon Stock Car Racing Association
(S.S.C.R.A)
P.O. Box 169
Saskatoon, Saskatchewan
S7K 3K4
(306) 651-FAST (3278)
www.autoclearingmotorspeedway.ca



Effective January 2015

Rule Moratorium in effect until October 31, 2016 except for Safety issues.

MISSION STATEMENT:

“To provide members a motor sports and entertainment facility to showcase their talents and abilities, while providing our fans, corporate partners, sponsors and media a valuable entertainment experience.”

RULEBOOK DISCLAIMER

The rules and/or regulations set forth in this book are designed to provide for the orderly conduct of racing events and to establish minimum acceptable requirements for such events. These rules shall govern the condition of all events, and by participating in these events, all participants are deemed to have complied with these rules. NO EXPRESSED OR IMPLIED WARRANTY OR SAFETY SHALL RESULT FROM THE PUBLICATION OF, OR COMPLIANCE WITH THESE RULES AND/OR REGULATIONS. They are intended as a guide for the conduct of the sport and are in no way a guarantee against injury or death to a participant, spectator or official.

The Competition Director together with Competition Committee, on behalf of S.S.C.R.A., shall be empowered to permit minor deviation from any of the specifications herein or impose any further restrictions that in their opinion do not alter the minimum acceptable requirements. NO EXPRESSED OR IMPLIED WARRANTY OF SAFETY SHALL RESULT FROM SUCH ALTERATIONS OF SPECIFICATIONS. Any interpretation of, or deviation(s) from these rules shall be left to the discretion of the officials. Their decision is final.

Saskatoon Stock Car Racing Association

(S.S.C.R.A.)

TABLE OF CONTENTS

CODE OF ETHICS

| | |
|--------------------------------------|----|
| GENERAL RULES..... | 1 |
| BACK GATE / PIT ENTRY | 1 |
| DRESS ATTIRE | 1 |
| NO PETS ALLOWED | 1 |
| PARTICIPANT SIGNATURE PAGE | 1 |
| PIT ENTRY – TRAILERS/HAULERS | 2 |
| TRANSPONDERS | 2 |
| RADIOS / RECEIVERS | 2 |
| BURNOUTS | 2 |
| CAR NUMBERS | 2 |
| ALTERNATE DRIVERS | 3 |
| FLAGS | 4 |
| TECHNICAL INSPECTION | 5 |
| POST RACE TECHNICAL INSPECTION | 5 |
| PROTESTS | 6 |
| SSCRA MEMBER PROCEURES | 8 |
| TRACK RECORD | 8 |
| DISPLAYS | 8 |
| APPEALS | 9 |
| GENERAL SAFETY RULES | 10 |
| DIAGRAMS | 12 |
| FORMS | 22 |
| PROTEST FORM | 22 |
| CRATE MOTOR REGISTRATION FORM | 23 |
| ADULT WAIVER..... | 24 |
| MINOR WAIVER | 25 |
| PARENTAL WAIVER | 26 |

CODE OF ETHICS

Purpose

To act in a professional manner so as to bring a positive image to the public and fellow members of the sport of stock car racing and to realize the need for a reasonable and responsible personal code of 'unwritten laws' since laws cannot cover all situations.

Expectations

1. As a member of SSCRA, respect, courtesy and cooperation must be shown to all fellow members, associates, sponsors and guests.
2. In any public setting, present SSCRA, its members and the sport in a positive light at all times.
3. Respect **MUST** be had for all traffic laws and criminal codes.
 - a) No alcohol, drugs, or stimulants allowed in association with your car or team when associated with any stock car event, display or promotion.
 - b) The S.S.C.R.A. reserves the right to ask for medical proof of health for any drivers or individual in the competitors' area.
4. No verbal or physical abuse towards any person when connected with a stock car event, display or promotion or when using social media.
5. All members should presentable when in any public situation.

Definition of Behavior

1. Anyone who, by word or deed, impedes, jeopardizes, or in any manner hinders the smooth and orderly presentation of the racing program or anyone who commits, or causes to be committed, any detriments to stock car racing, and/or the S.S.C.R.A. will be considered to have abused the privileges of membership or event participation,
2. Entry and/or admission granted by the S.S.C.R.A. and that they may be subject to the revoking of those privileges and/or disqualification as deemed proper by the Executive or designated official.
3. **Drivers are responsible** for the sportsmanlike conduct of anyone in their crew and penalties incurred by a crew member may affect the driver, and or the registered owner.

General Rules

1. **BACK GATE/PIT ENTRY**

- a) All people in the competition area **MUST** be members of the S.S.C.R.A. except as provided for visiting members from another club and/or traveling series invited by S.S.C.R.A.
- b) All persons entering the competition area including officials **MUST** sign a release waiver.
- c) Anyone under 18 entering the pit area **MUST** have parent's written permission to enter pit area during competition.
- d) No one under the age of 12 years is allowed in the pit area during competition unless registered as a Bandolero driver.
- e) BANDOLERO participants will be permitted entry to the pits at 8 years of age. Actions and behaviour of junior members will be monitored. Parental Waiver required with BOTH parents signature for all individuals under age 18. Pit entry privileges may be revoked if warranted.
- f) ACMS reserves the right to limit pit entry to **eight** people, including the driver, with each car/truck per race night.
- g) Entry to the pits will be granted once the **back gate fee has been paid and waiver signed**.
- h) **NO Season Tickets, NO Flex Tickets** or other promotional tickets will be accepted at the back gate entrance.
- i) Back Gate will be closed at one hour before the scheduled start time on that given event. Once gate is closed, pit crews or drivers must enter from Fan Side. **See Fan Side Manager for entrance and signing of waiver**.
- j) It is the driver's responsibility to inform their crew of the rules and regulations. Fines will be levied against the car/truck driver/owner.
- k) While a race is in progress, **NO ONE** will cross the track. (Moved from 43)
- l) Drivers without a valid driver's license may apply to the Executive for approval to compete. Anyone under 18 years of age **MUST** have both his/her parents' written permission to race. If a driver's license is revoked, only the S.S.C.R.A. Executive can make reinstatement to race.
- m) Drivers are allowed two (2) Local Regular races plus Invitationals; then they must register.
- n) For Local races ALL cars must meet the local rules and must be legal to get the Feature Flag.

2. **DRESS ATTIRE**

- a) No person shall be admitted to the pits unless they are appropriately dressed: shirt with minimum three inch sleeves, **minimum** knee length shorts, but full length pants are recommended.
- b) Closed toe shoes only. (**no sandals or flip flops**)
- c) Any person dressed improperly, will be asked to dress with proper attire or leave the pits for the remainder of the race meet.
- d) Pit crew and driver clothing **MUST** be clean. Violators are subject to a fine.

3. **NO PETS ALLOWED IN PIT AREA or on Concourse on FAN SIDE.**

It is the competitor & participants' responsibility to fully understand the General Rules & Safety Rules in addition to the rules that apply specifically to their race division. Please review the Rules Package applicable to your Division.

4. PIT ENTRY trailers/haulers

- a) Cars will not be allowed to compete unless they are hauled/towed to and from the track.
- b) Race cars **MUST** be unloaded in the pits / competitors parking before the back gate closing time scheduled on race day.
- c) All race cars must remain in the pit area until **30 minutes after** the final race of the program has finished. Cars may enter and leave at other times by permission of the Competition director or the appointed official only.
- d) Division Pit stalls and parking areas will be appointed and laid out in race day schedule. Exception at discretion of Competition Committee to accommodate duo division teams.

5. TRANSPONDERS

- a) All cars/trucks in competition will be provided a transponder by SSCRA for a rental fee. Transponder rental fees will be paid at the back gate but provided at the tech booth each race day.
- b) Rental transponders must be returned at the end of each race meet. Drivers will be responsible for any lost or damaged transponder.
 - i. Transponders **not returned** after evenings race program will result in a possible penalty or full replacement cost of transponder.
- c) Mounting location will be determined by Tech Committee.

6. RADIOS or RACEIVERS

- a) Raceivers are mandatory in all divisions and must be working at all times when car is on track.
- b) In divisions which radios **are allowed**, either spotter or driver must have the capability of receiving this said given frequency at any given time. Spotter with this device must have direct communication with their driver.
- c) In Divisions where radio communication is allowed, only one spotter that is in radio contact with a car currently racing will be allowed on an elevated platform in the pits and/or one on the tower.
- d) If the spotter does not relay the information to the driver or the driver doesn't respond in a timely manner the car will not be scored.
- e) Any platform that is more than 24 inches above ground level must have a 42 inch high guard rail on all sides. Only properly designed platforms will be allowed. i.e. no standing on tires, chairs, etc.

7. **No vehicles**, other than the cars competing and track service vehicles, will be allowed in the pit area during competition.

8. **Cars left in the pits** over 24 hours will be considered abandoned and become property of the S.S.C.R.A. Unless permission from Competition Committee or appointed official.

9. **Stationary** burnouts on the race surface will result in a minimum **\$125.00 fine**.

10. Car Numbers

- a) All numbers are assigned and are property of the S.S.C.R.A.
- b) Car numbers will be limited to a maximum of two digits, a third digit or letter maybe used with permission from the Competition director or the appointed official.
- c) Numbers must be clearly legible and **Must** appear on both doors and roof:
- d) **Minimum 18" high x 18" wide with a four (4) inch stroke.**
- e) **Must** appear on the left head light and right tail light of car at least 4" tall.

- f) If a number cannot be read from the main tower to the back straight, it will have to be changed.
 - g) If a current member has a number for that year, they retain that number next year, providing they register their car by opening day. or if they miss the next year, they may have that year as a grace period. If they return the following year prior to race season opener with a registered car they would retain the number. If not, they lose rights to it.
11. **Out-of-town and non-registered** cars **MUST** change their car number for that specific race day if their number conflicts with a local car number.
 12. The top portion of the windshield in all divisions is reserved by the SSCRA for club and/or division **sponsorship banners**. No marking or decals are to appear below the banner.
 13. All cars competing, whether from different tracks or previous years, **MUST** comply with the current S.S.C.R.A. rules to receive local points and/or payouts/prizes/feature flag.
 14. **Visiting cars DO NOT receive local points.**
 15. **Teams running alternate drivers during a race day MUST advise the back gate and the Competition Committee or his designated official as to who is running which heats and the feature race. Alternate driver must be named on Registration Form.**
 - a) Any driver change, other than named alternative, must start at back of the pack but will maintain points. Named alternative drivers maintain their position.
 - b) **Driver changes at the track** during the event may occur going up, down, or within a division as long as the race director gives permission.
 - c) The car **MUST** start at the rear of the lineup for the remainder of the event. All points go to the registered driver/car combination; last place points will be awarded.
 - d) In case of medical reasons or a scheduled absence, Competition director or the designated official may approve a replacement driver with points going to the registered driver/car combination.
 - e) Line up and positioning for qualifying and/or races is the responsibility of each race team. for knowing which race and what position to be in rests with each car's crew.
 16. **Late for line-ups:** Any car late for a lineup will be placed at the back of the lineup. Exceptions are at the Competition Director or appointed official's discretion only.
 17. **No working on the car in the staging lane.**
 - a) One crew member allowed per car/truck in the staging lane. Crew member to remain positioned at the left side of the car/truck.
 - b) Other exceptions only at the Race Director's or Competition Director or appointed official's discretion, including refueling.
 - c) Only Super Late Model / Super Trucks will be allowed to adjust tire pressures prior to entering the race track. Portable air tanks & air pressure gauges only will be allowed on staging lane.
 - d) Anyone holding up advancement pre-staging will be put to the rear of the field.
 18. Some races may be designated as using the staging lane as '**hot pits**'. The hot pits are separated from the main pits by the concrete barrier. No crew member may go over the barrier into the hot pit until their **car has come to a complete stop. No more than three crew members in the hot pit at any time.** The car may not leave the hot pit until all their crew members are back over the barrier.
 19. The Competition Committee will make up race day schedules and reserves the right to alter the race schedule during the event to accommodate unforeseen circumstances.

20. **The Race director and/or the flagman are in complete charge** of the races. He has the authority to disqualify any cars obstructing the race as he sees fit.

21. The **Start/Finish line** will be the center of the front straight.

22. Flags:

- a) Any disregarding of the flags will result in a penalty, fine and/or suspension.
- b) **Race “go” line on flag drop** is from yellow line on track in corner four (4) to start/finish line. The race is started when flagman throws green flag.
- c) **Green:** The waving of the green flag signals the start of the race. A rolled up green flag displayed during warm up laps indicates the race will start on the next lap (green light).
 - i. **Rolled up one to go means green next lap, no exception. In the event of a ‘jump start’ the green flag flies, caution flag will be thrown the next lap and then a complete restart takes place**
- d) **Yellow:** CAUTION – Indicates an incident has occurred that is a hazard to the cars/drivers in the race.
 - i. The caution flag will be given to the first car passing under the flagman.
 - ii. Restarts are determined by the last completed green flag lap; restart lap is started by position one.
 - iii. Any car involved in an accident will start at the rear of the field, unless “Tap-Out Rule” opted by instigating car.
 - iv. Cars pitting while the race is under caution will rejoin the field at the rear (yellow light).
- e) **Red:** Indicates drivers are to stop even with and to the right of the flagman displaying the red flag (red light).
 - i. No car may enter the track while the track is under red.
 - ii. Work can continue on any vehicle already in the pits prior to red flag.
 - iii. Work can commence on any vehicle entering the pits while the track is under a red flag condition.
 - iv. Once the red flag is lifted and track goes to caution the vehicle may enter the track under official’s direction.
- f) **Black:**
 - i. A rolled up black flag pointed at any car during a race serves as a warning that an infraction of the race rules has occurred.
 - ii. An open black flag directed at any car means the car must immediately leave the race and report to Staging Lanes at Start/Finish Line. The Infield Official under direction from the flag man will give explanation of penalty; you may be instructed to go to the back of the field or parked for that race.
 - iii. For all open black flags, your car number will be flashing on the scoreboard. You have three laps to leave the track and report to the Competition Director*. After three laps disqualification from the race is automatic and you will no longer be scored for the balance of the race.
 - iv. If you receive 3 open black flags for that race event you will be disqualified for the remainder of that race event.

- v. Any car disqualified from a race will start at the back of the pack for the balance of the race event or the first race of the following race event if disqualification was in the feature.
- g) **Black with yellow dot**: Indicates a mechanical or structural problem with your car that is a hazard to yourself or other cars in the race.
 - i. You must immediately report to your pit to have the problem corrected.
 - ii. The car may not re-enter the race until cleared by your division's technical inspector or a race official.
 - i. Your car number will be flashing on the scoreboard. You have three laps to leave the track. After three laps, disqualification from the race is automatic and you will no longer be scored for the balance of the race.
- a) **Blue**:
 - i. Indicates you are being lapped and must hold your race line; **either high or low**, permitting cars to pass uninhibited.
 - ii. You may also be blue flagged if your are purposely blocking or obstructing cars from passing. If you disregard the blue flag; under discretion of the flag person you may be black flagged.
- b) **White**: Is displayed to the leading car and indicates one lap remains in the race.
- c) **Checkered**: Is displayed to the leading car and indicates the race is complete.
 - i. If you are running under a caution flag, you **MUST** get the green, white and checkered flags, before the race is complete; not to exceed two (2) attempts.

25. 'First lap' caution

- a) In the event a caution is necessary before the first lap is complete, there will be a restart based on the original starting lineup-
- b) First false start the offender will maintain his original starting position; second false start by the same individual the offender will be sent to back of the field.

26. A **race is deemed complete** after 50 percent of the scheduled laps have been completed if a race needs to be halted before race length is completed. *i.e. rain or in excess of allotted time limit*

27. A penalty of \$50.00 will be issued to anyone who inquires about race results before posting. Any attempt to destroy or impair tower official's capacity for collected thought or decisive action will result in a \$50.00 fine.

28. Technical Inspections: Omission of any technical/mechanical rule does not imply it is legal.

- a) ALL cars competing **MUST** go through tech inspection **BEFORE RACING**.
- b) S.S.C.R.A. registered cars/trucks **MUST** be checked on designated tech days, otherwise a \$100.00 fee will be charged for a non-scheduled tech inspection.
- c) No initial teching will be performed on race night for non-teched cars, unless prior arrangements are made with the Competition Committee or the division tech.
- d) The driver/owner of the car is responsible to make their car conform to S.S.C.R.A. rules.
- e) All Tech equipment that is owned and used by the S.S.C.R.A. Competition Committee will be considered FINAL, no protests will be accepted!

29. If you have a tech problem not specified in the rulebook, contact the Competition Committee for your division and receive a written opinion.

30. Post-Race Technical Inspections

- a) The top five local or out of town cars must report to tech lane immediately after the feature race without stopping in the pits.
- b) Any car finishing in the top five positions of a feature race that does not report to the technical inspection station immediately on leaving the race track will be disqualified. This will result in loss of prizes and possible suspension.
- c) All illegal parts will be confiscated and become property of S.S.C.R.A.
- d) Refusal to comply with tech will result in immediate suspension of the car and number for the remainder of the year.

31. Scales

The scales owned by the S.S.C.R.A. when used in the locations permanently marked on the inspection pad at Auto Clearing Motor Speedway are the benchmark and will determine the actual weight and weight percentages of all cars.

- a) **If a car is found to be illegal**, that car will lose the points and any prizes / feature flag / money earned at that race meet plus 15% of the total points to date.
- b) For a second offense, the car will be penalized as above and additionally receive a two race meet suspension
- c) Any car that fails the weight and/or measurement requirements for their division will lose any points and/or prizes / feature flag / money earned for the race where the infraction occurs.

32. Noise Levels

- a) It must be recognized that Auto Clearing Motor Speedway is in a jurisdiction that has a **noise bylaw**. Procedures will be in place to abide by these laws.
- b) All cars/trucks competing **must have a muffler** and will be subject to a maximum noise level of 98 decibels.
- c) Decibel readings will be taken in the pits and stands at a designated location with a decibel meter owned by the S.S.C.R.A. to insure conformity to the by-law.
- d) This meter will be the standard for all cars/trucks.
- e) Cars/trucks not meeting the standard will have one race to meet standard. If no action is taken to conform to the rule, the offending car will not be allowed to compete until correction is made.
- f) The Race Director can shorten scheduled races that extend beyond a reasonable time to ensure all racing is complete by 10:00pm, unless an extension has been specifically granted by the RM for that date.

33. The SSCRA Competition Committee reserves the right, in the Spirit of Competition, to add devices to any vehicle to equal competition.

34. Protest

- a) A car driver may file a protest against a single car within their division. Only one car protest per team per race event is allowed.
- b) All protests (relating to teching or finishing positions) **MUST** be submitted to the Competition Committee or designated official within 30 minutes of the conclusion of the final race of that day.
- c) Protests **MUST** be submitted on the official protest form available from the competition committee. All protests to be written, signed by the driver, and accompanied by the required fee (cash).
- d) Competition Committee will rule on the protest by the Wednesday following the protest.

- e) The fees will run as follows:
- i. \$200 Chassis and suspension inspection **or**, Cylinder head, intake, camshaft, exhaust, and carburetor (top end) inspection **or**, clutch, transmission and differential ratio inspection.
 - ii. \$300 Cylinder head, intake, camshaft, exhaust, carburetor, oil pan one connecting rod, piston and crankshaft.
 - iii. \$350 Dyno test of horsepower only of a sealed crate engine in applicable divisions. This is a service only and no monies will change hands whatever the outcome of the test results is. Monies are non-refundable!
- f) There **MUST** be one spokesperson from the protesting car present during any dispute or tear down of the vehicle.

35. In the event of a **sealed crate engine problem**, the following procedure will be enforced.

36. A **supervised** engine inspection will be performed by a member of the Competition Committee. The installation of engine components must be supervised and **SSCRA seals** will be installed. **ALL components must be Genuine to the Manufacturer specifications for that engine and proof of component part numbers must be provided to the inspector.** In the event of “any” machining must be done (resurfacing block or cylinder head), the engine part must be replaced. **All costs of travel** for the inspector will be covered by the individual who requests this service.

37. For Compliance procedures refer to SSCRA Crate Engine Registration.

S.S.C.R.A. Members Procedures

1. Track Record.

- a. Permission MUST be granted one week prior to an attempt to set a track record. The time trial will be held one half hour prior to the race event start time.
- b. The car/truck must immediately report to tech following the record attempt. If a track record is set during scheduled time trials, the cars/truck will be waved to tech.
- c. No track record will be awarded until the car/truck passes technical inspection.

2. Displays:

- a. Any displays involving more than one member and car MUST have the approval of the S.S.C.R.A. Executive or the Advertising and Promotions Committee.
- b. No one is allowed to use the Bridge City Speedway Inc., Auto Clearing Motor Speedway or S.S.C.R.A. credentials, which are the property of the S.S.C.R.A., without the permission of the S.S.C.R.A. Executive.
- c. Any violation of this rule may result in suspension.

3. Trophy / Awards:

- a. **"Rookie of the Year":**
 - i Rookie of the year trophy will be awarded to the eligible driver who has the most points and who has raced a minimum of 80% of that year's race.
 - ii Eligible drivers being anyone who has not competed in more than 3 race days in that division in any previous year.
 - iii Rookie status drivers can move upward in divisions from Mini Stock to Street Stock to Pro Truck to Sportsman to Super Late Models, but cannot move down.
 - iv Rookies MUST register on driver's application forms at the start of the year so executive can review qualifications.
 - v If anyone other than the registered rookie driver races the car during the year, the race director MUST be informed and rookie eligibility will be forfeited.
 - vi Any alternative driver must also meet Rookie Status for that division.
 - vii Rookie Drivers must run Yellow Rookie Stripe on rear bumper.
- b. **"Most Improved Driver", "Best Looking Car & Crew", "Most Courteous Driver" and "Phoenix Award"** will be voted on by the drivers in each division by ballot.

4. In the event of behavior unbecoming of an S.S.C.R.A. member (not complying with the Associations' set Code of Ethics), the Executive will review the privilege of membership. The Executive will decide if censure, written warning, probation, suspension, or revocation of membership is to follow.

- a. Any actions felt to be intentional to harm a competitor's car in non-competition will result in suspension and/or fine.
- b. Any action felt to be intentional to harm a fellow member will result in either expulsion, suspension and/or a fine.
- c. Any verbal or physical altercations in the public eye will result in suspension and/or a fine.

5. **Swearing, abusive or ungentlemanly conduct towards or any Association official is subject to an immediate suspension of two race meets and/or a fine. Any physical contact will bring an automatic one-year suspension from the S.S.C.R.A. from the date of the offense. All S.S.C.R.A. members are responsible for their own fines and the fine is to be paid before the next race day or the offender will be refused pit entrance.**
6. ALL persons in the competitor area are not to be under the influence of or in the possession of stimulants, illegal drugs or alcohol proceeding, during or after a race. Offenders will be suspended for two race meets for the first offense and for the remainder of the season for the second offense. Breathalyzer and urine samples may be requested and refusal to comply will result in a three race meet suspension.
7. All rulings made by the S.S.C.R.A. Executive are final. If one of the Executive is being protested, they **MUST** step down while the matter is handled by the rest of the Executive.
8. Notice of infraction of any of the rules may be issued by any Race Official. Where provided, fines and/or discipline is automatic. Where a fine or discipline is not defined in these rules, the matter will be decided by the Competition Committee or the Ethics Committee as appropriate.
9. **The right of appeal** is given to any member of the S.S.C.R.A. who has been disciplined for any infraction of rules, regulations, or specifications of the S.S.C.R.A. with the exception of a black flag.
10. The appeal must be filed in writing by the Wednesday following the notice of discipline. The appeal will be heard by the next Wednesday and a decision rendered before the next race meet. The Appeal Committee will consist of the President, the First Vice-President and the Second Vice-President. The Appeal Committee shall select a Director to act as an alternate in the event one of the above must stand down due to a conflict of interest.
11. **All cars/trucks MUST** provide at least one representative for opening and closing work parties and as scheduled by the director of volunteers.

General Safety Rules

1. **Fire Extinguisher (car):** Optional: every car may have a 2.5lb (1kg) fire extinguisher with a recharge slip back-dated no more than 12 months. The extinguisher **MUST** be mounted securely with a metal quick release mechanism or fire system release cables mounted within reach of the driver with seat belts fastened.
2. **Fire Extinguisher (pit):** Every car **MUST** have a 5lb (2.5kg) fire extinguisher with a recharge slip back-dated no more than 12 months accessible in the pit area.
3. Only left hand drive vehicles may participate in race events. Racing shall take place in a counter-clockwise direction only on the track.
4. All bars and components that the driver's head or limbs may come in contact with **MUST** be **padded** with a suitable crushable material. No water pipe insulation. The steering wheel center, including OEM steering wheels, **MUST** be padded with a minimum of 2" of approved crushable material.
5. **Automatic Transmission:** Any car in any division with an automatic transmission **MUST** have a neutral safety switch, which may be routed through the brake light switch.
6. **SFI approved oval track racing bucket seat** with head support, properly mounted to the roll cage is mandatory. Aluminum.
7. **Seat Belt**
 - a) Every car **MUST** be equipped with a 5-point quick release seat belt. Shoulder mounts **MUST** be mounted level with the shoulder to four inches below shoulder and in accordance with manufacturer's instructions. Seat belts to be anchored to the seat mount and/or roll cage at a 45-degree angle with reference to the floor of the car. Crotch strap to go through the seat and anchor behind the driver's chest line. All belts **MUST** be mounted to the seat mount and/or roll cage. See diagrams C1, C2, C3, C4, and C5.
 - b) Minimum 2" wide belts are mandatory in all divisions. All belts **MUST** be clearly labeled and dated by the manufacturer. Systems **MUST** be updated at 4-year intervals from the date of manufacture in Super Late Model division and Sportsman, 5-year intervals in all other divisions.
 - c) Seat belts will have to be changed prior to the prescribed frequency if they exhibit wear or fraying of the fabric.
 - d) Seat belts must be worn at all time on the track.
8. **Window Net:** Every car **MUST** be a quick opening type from an approved manufacturer, equipped with a **TIGHT** driver's side window net. Net **MUST** be web style and quick opening, complete with mounting rods composed of minimum 3/8" steel rod. Attaching points **MUST** be of equivalent strength and mounted to roll cage. Window nets must be 'up' at all time on the track.
 - a) Mini Stock: Passenger side window protection **mandatory**, device may be a quick release similar to driver's side window net to allow access for safety crew. Push button type release may also be used on passenger side subject to discretion and approval of Competition Committee.
9. **Racing Suit:** All drivers **MUST** wear a minimum single layer certified racing suit. Super Late Model and Sportsman drivers **MUST** wear a two-layer certified racing suit. A single layer certified racing suit with full Nomex underwear is acceptable as two layers. Racing suits exhibiting excessive wear or abuse must be replaced.
10. **Helmets** for all divisions **MUST** meet Snell-SA2000 specifications or equivalent. Snell 2010 helmet recommended for 2015, mandatory in 2016. Half-shell helmets are not permitted. Full face, Snell Automotive Sports (SA) design helmets are recommended. Fire retardant balaclava recommended.

11. **Mass produced head and neck restraint systems mandatory** in all divisions. A neck collar does not qualify as a head and neck restraint system. Exception: for the Enduro and Street Stock Invitational the minimum requirement will be a neck collar.
12. **Eye protection mandatory in all divisions.**
13. **Fire retardant driving gloves are mandatory in all divisions.**
14. **SFI certified racing shoes are mandatory in all divisions.**
15. Any protective gear exhibiting excessive wear, holes or abuse must be replaced.
16. **Lights (Optional):** Brake lights are not permitted.
17. No rear **window louvers** allowed. Front and rear windows must be unobstructed and kept clean.
18. When a collision or rollover occurs, **ONLY THE SAFETY CREW WILL BE ALLOWED NEAR THE CAR.** The ambulance crew or first aid attendants will first determine whether to remove the driver from the car before righting it. (There is a chance of serious injury to the driver when being removed if internally injured.) The tow truck will move the car to right it. All drivers in competition **MUST** remain in their cars until the race is completely stopped. Anyone finding that for any reason he/she cannot continue to race should leave the racing surface to avoid jeopardizing themselves or other competitors.
19. The officials or the flagman may disqualify cars containing loose objects or any other items that could be a detriment to other competitors.
20. **Speed limit** in the pit area, including the staging area, is 5 mph (8 kph). No excessive wheel spinning. Violators are subject to a fine.
21. Any safety violation will result in a one-race meet suspension and/or fine, pending discretion of Competition Committee.

Appendix A

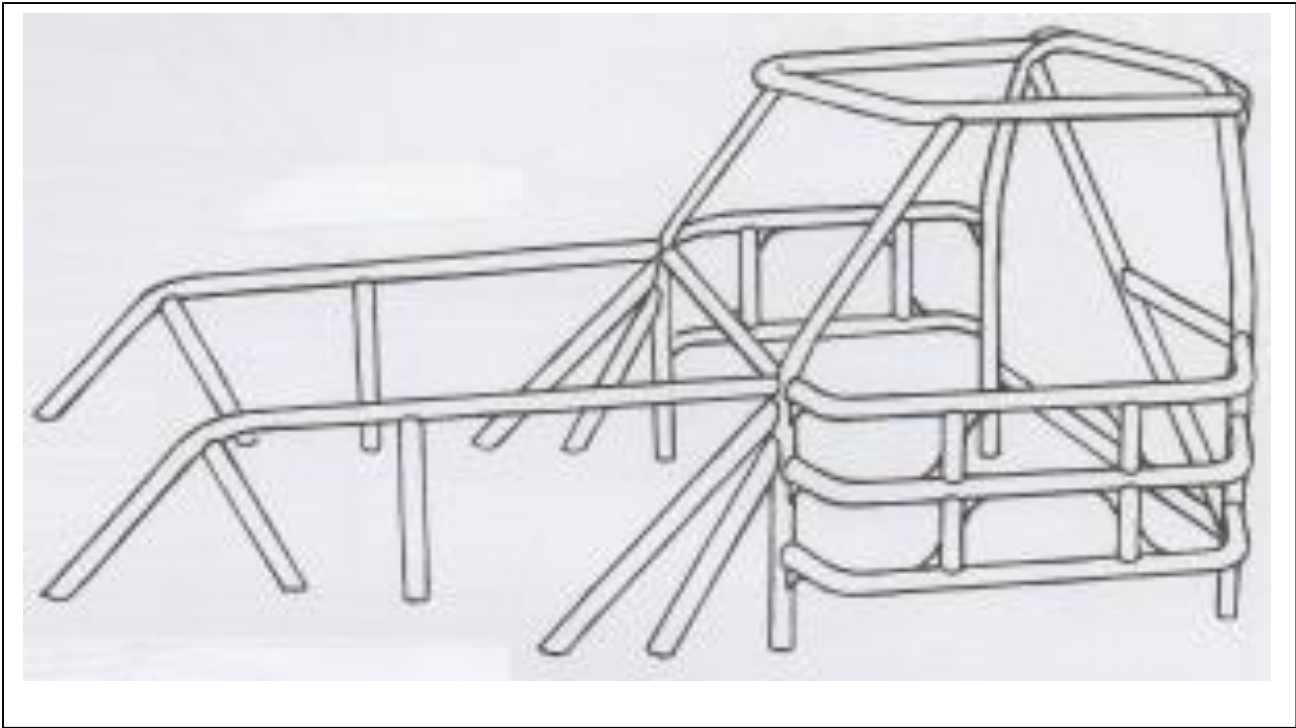


Diagram 1A

Halo Cross Bar – Straight or Diagonal

Door Bar to Window Pillar

Earnhardt Bar

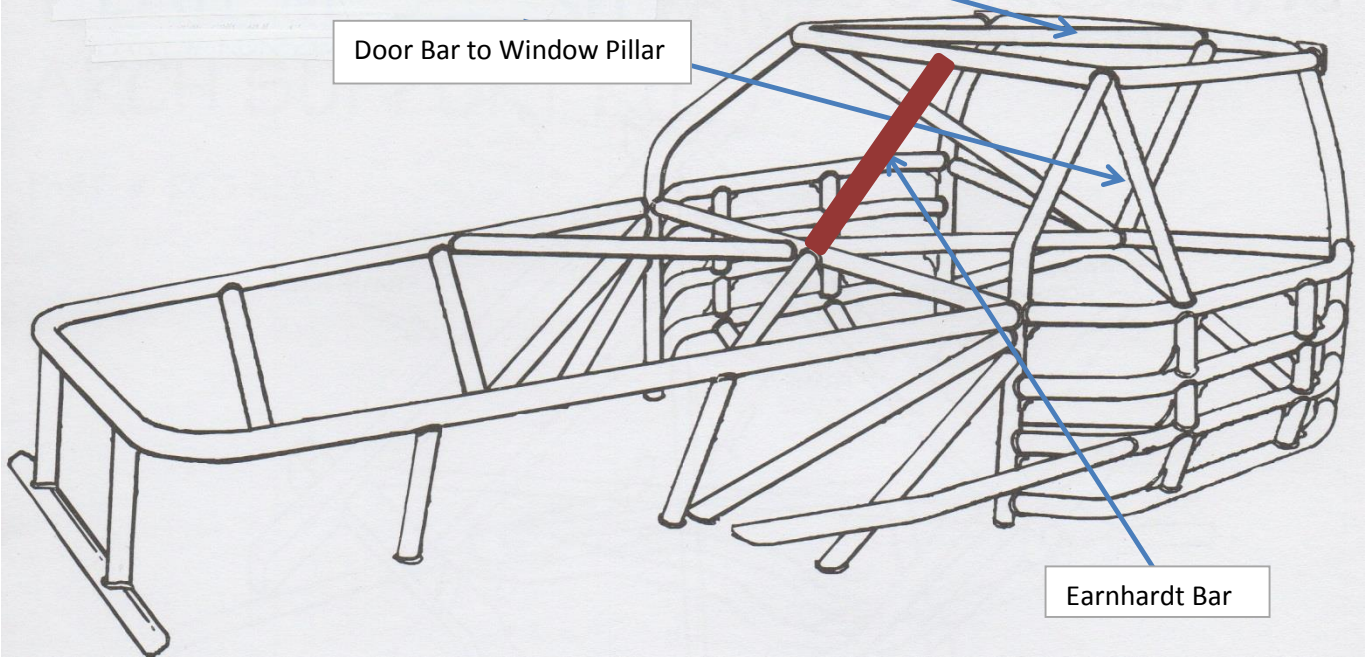


Diagram 2A

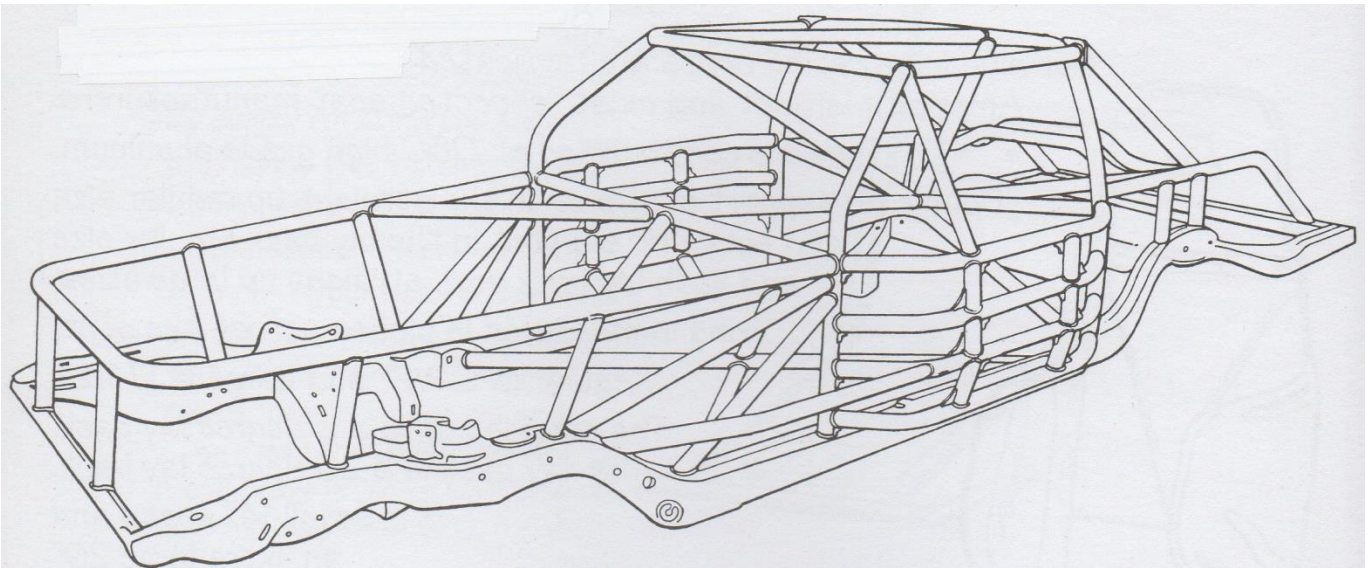


Diagram 3A

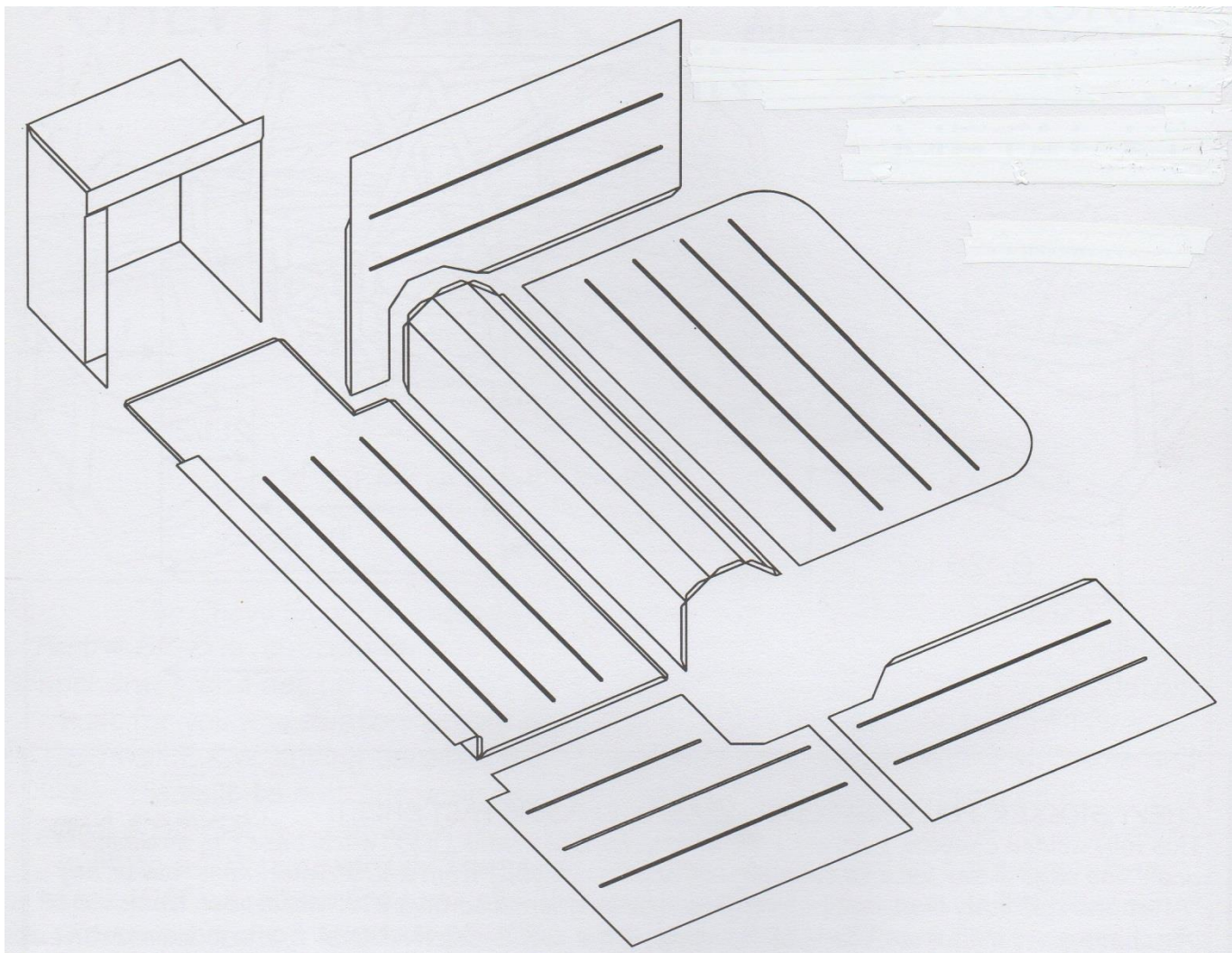


Diagram 4A

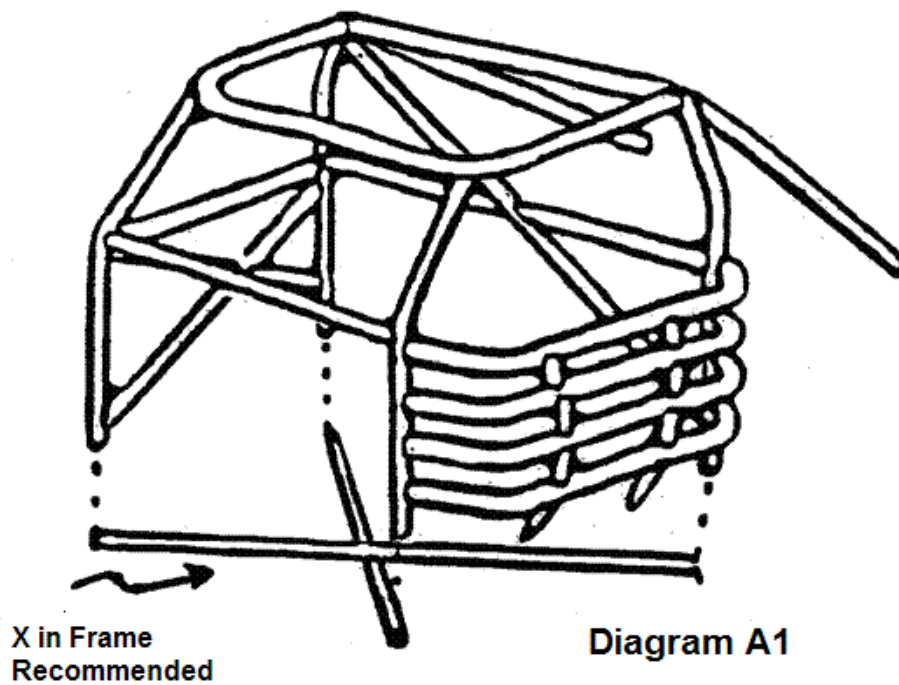


Figure A1

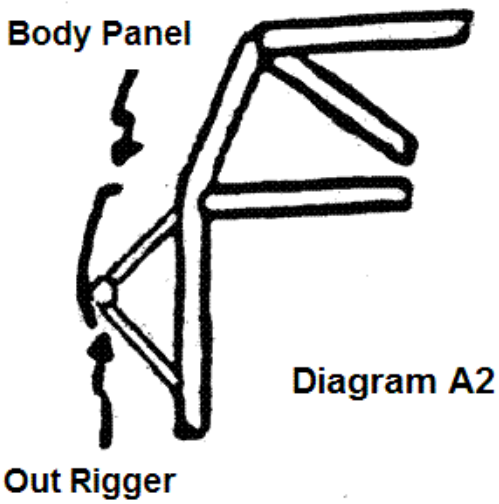


Figure A2

Appendix B

Diagram B1

Acceptable method of splicing tubing structure

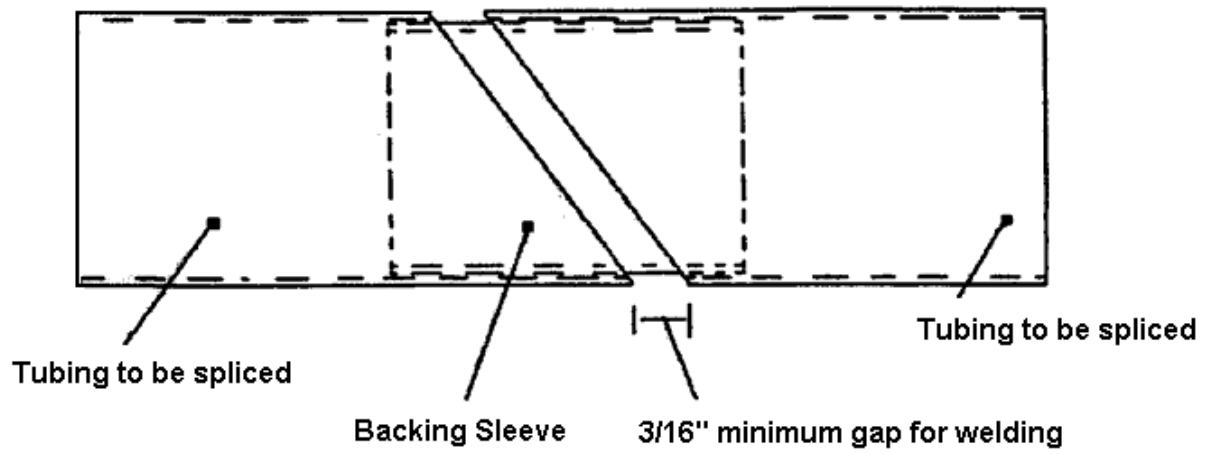


Figure B1

Tubing supported bumpers or covers

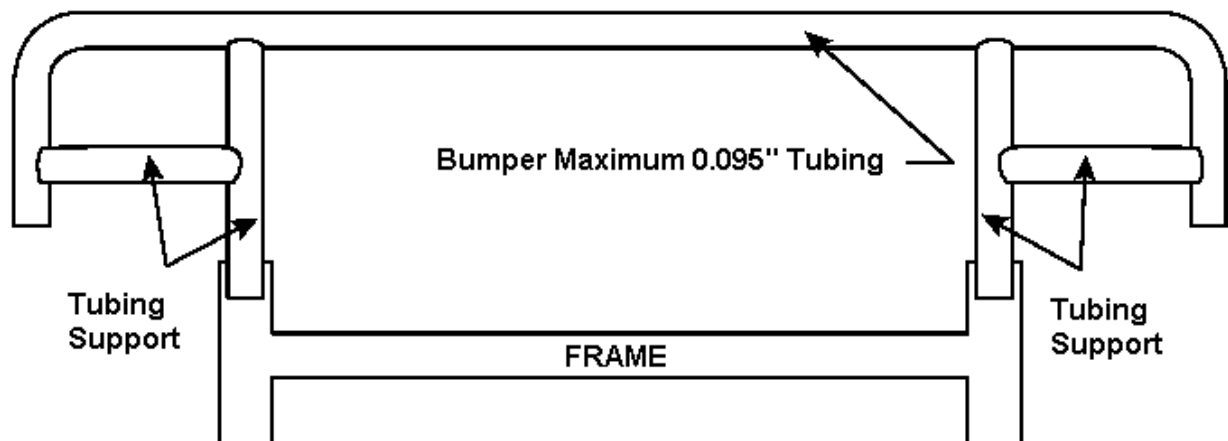


Figure B2

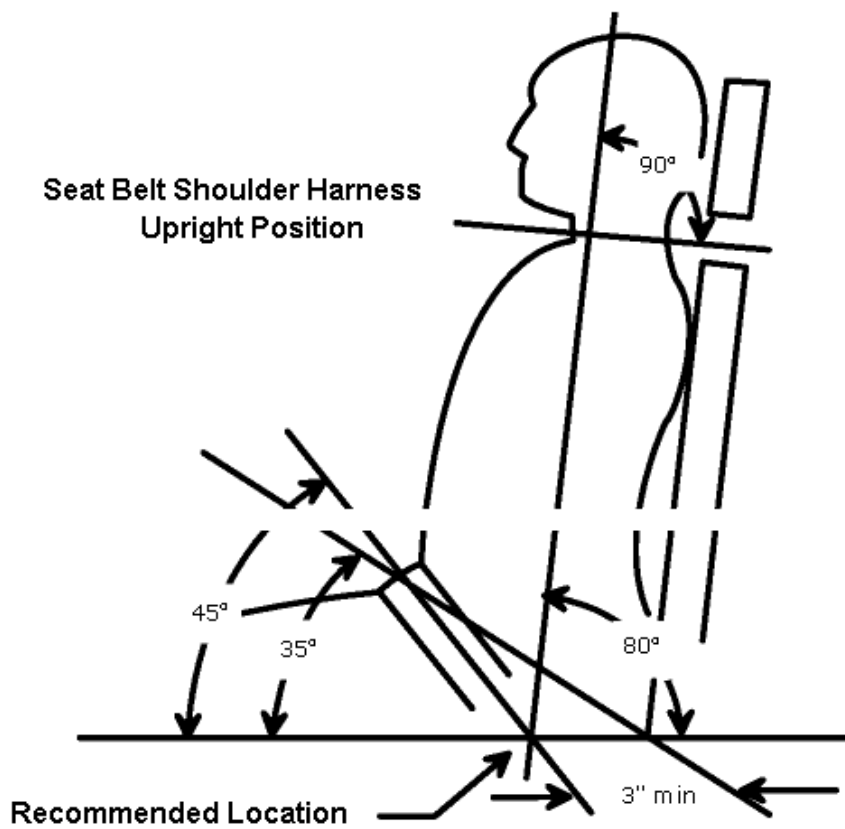
Appendix C

Figure C1

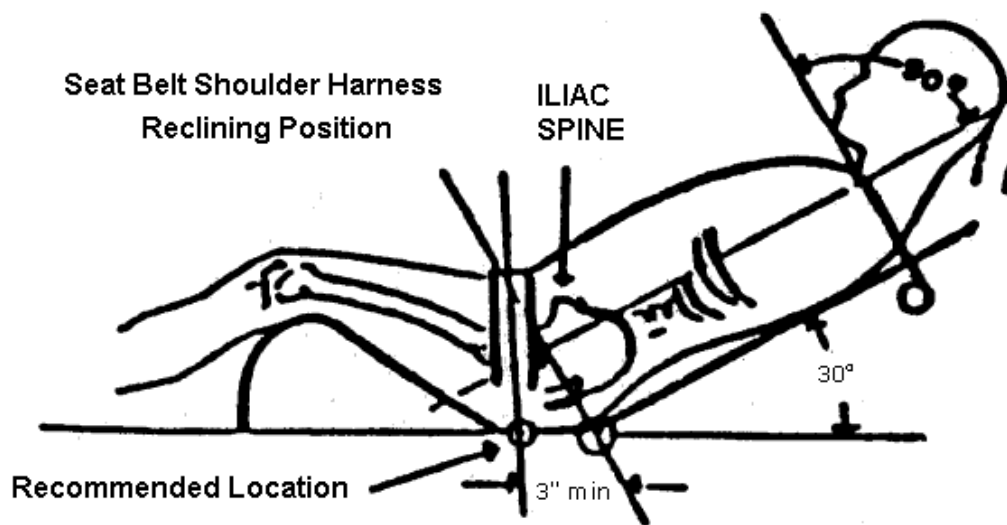


Figure C2

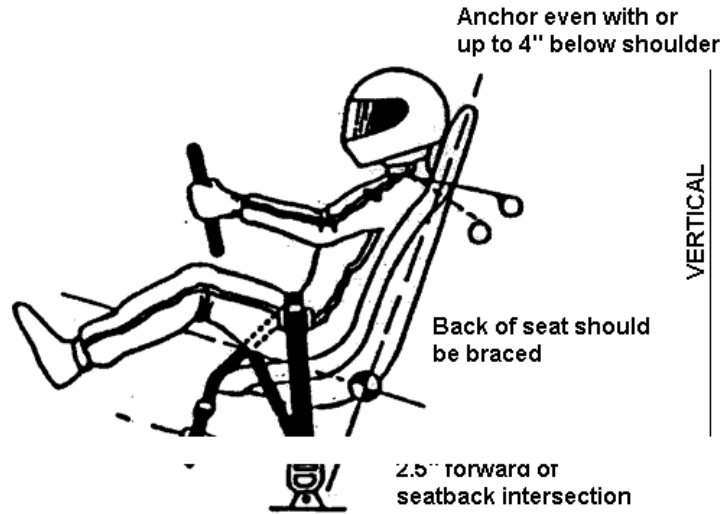


Figure C3

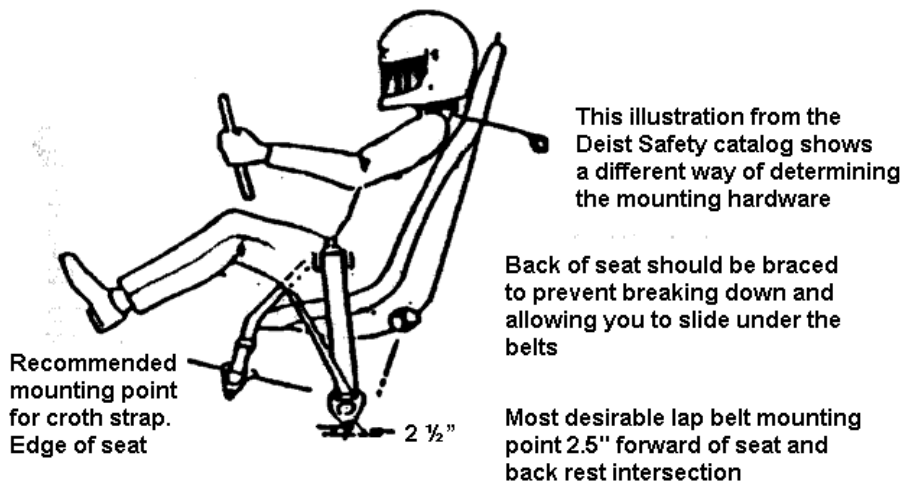


Figure C4

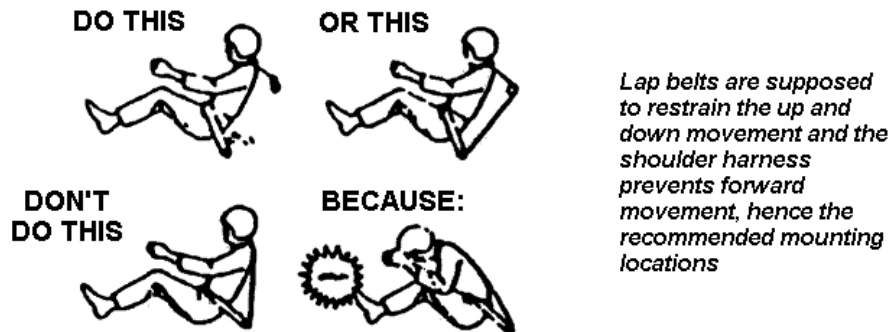


Figure C5



Diagram 5A

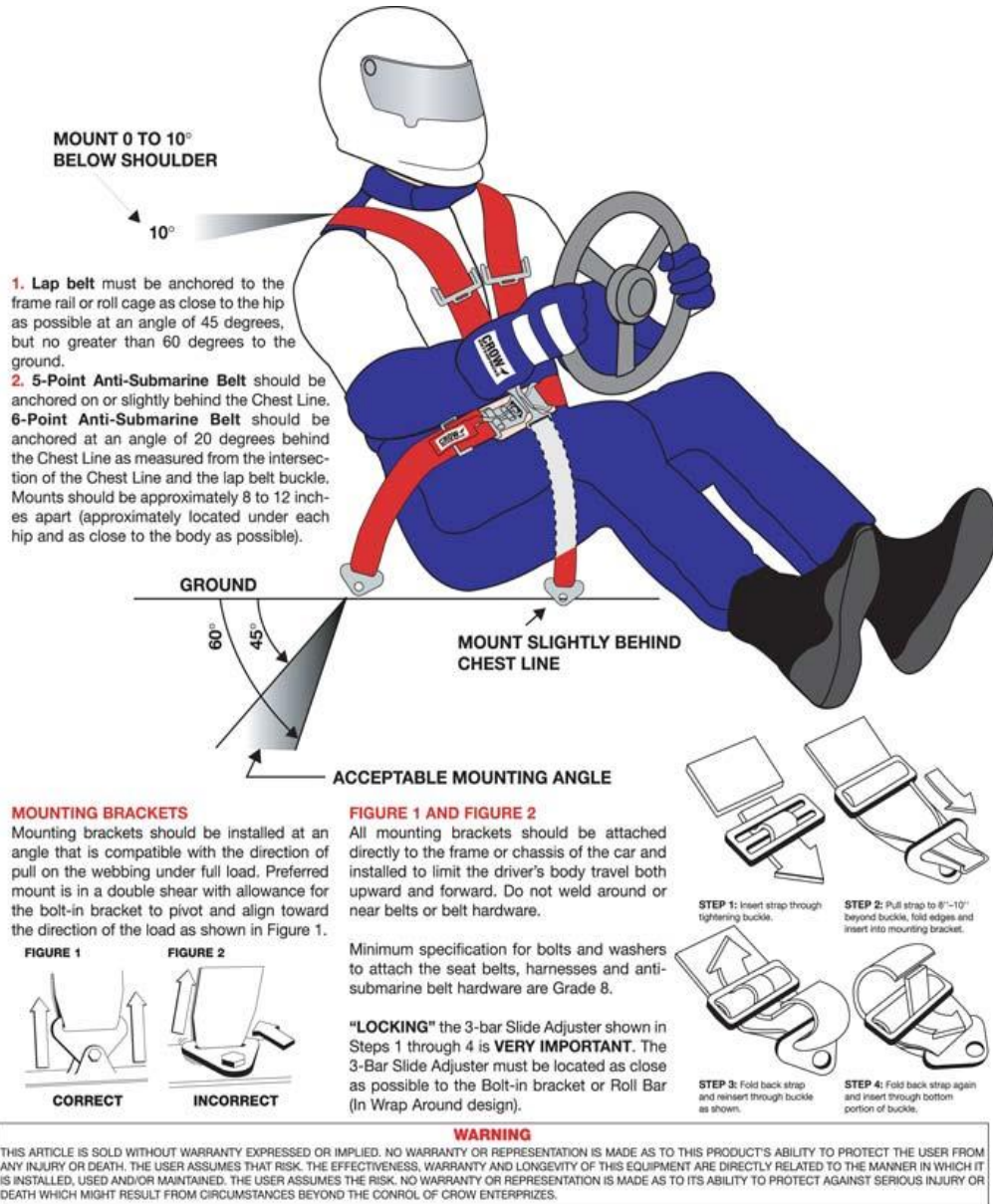


Diagram 5B



Seat Mount Diagram 6A



Recommended Seat Diagram 6B

Saskatoon Stock Car Racing Association Protest Form



Race Date: _____

Division:

- Super Late Model
- Sask Legends
- Sportsman
- Mini Stock
- Street Stock
- Pro Truck

Protest Against (Name): _____

Protest For: _____

Reason for Complaint: _____

Protest Fee:

- \$200 – chassis and suspension inspection or, cylinder head, intake, camshaft, exhaust and carburetor (top end) inspection or, transmission and differential ratio inspection.
- \$300 – cylinder head, intake, camshaft, exhaust, carburetor, oil pan, one connecting rod, one piston and crankshaft
- \$350 – Dyno testing of sealed crate engine for horse power rating only

Protester's Name: _____

Protester's Signature: _____

Cash Collected By: _____

Technical Inspector/ Race

Director Signature: _____

Protest Results: _____

⇒ **Protest forms must be turned in to the Technical Inspector or Race Director 30 minutes after the conclusion of the final race.**

⇒ **All teardowns will be arranged with all parties.**



SSCRA CRATE ENGINE & OPEN ENGINE REGISTRATION



Spec Engine Owner: _____ Team # _____

Driver: _____ Division: _____

All Competitors Competing in any SSCRA Event Must Complete this agreement.

Serial Number

SSCRA Serial Number

Crate Engine #1 _____

Crate Engine #2 _____

Crate Engine: P/N GM 88958602, GM 19258602, GM 88958604, GM 19318604, P/N Ford BP3472CT.
Open Engine. *Please circle one.*

By registering and signing this agreement, you will be allowed to compete and receive prize money and points at SSCRA events. There will be NO prize money or points issued without registering spec engine with SSCRA Competition Committee prior to competing.

AGREEMENT:

1. I agree to the policies regarding the SSCRA Crate engine program and open engines, as outlined in the SSCRA rules and regulations, procedural manual, this registration, and/or any other requirements which might be established.
2. I understand that the SSCRA Crate Engines are not to be tampered with. Any unauthorized breaking of the seals or unauthorized freshening or altering in any way is a violation of the SSCRA rules. Anyone caught tampering with seals on a sealed crate engine or otherwise cheating with a sealed crate engine in any division will be subject to a one year suspension and the engine confiscated as above.
3. I understand that by registering my crate engine(s) and/or open engine(s) and using it/them to compete in any SSCRA-sanctioned event, I, or my assigned driver(s), are subject to any and all penalties which might be imposed from time to time by the SSCRA organization.
4. I agree to abide by the SSCRA policy that a crate or open motor may be siezed for inspection (dyno'd) at any time. If the integrity of the said motor is not fully in compliance with the SSCRA rules and regulations, I further understand that I am subject to penalties which may be imposed by SSCRA, and my privilege to compete may be forfeited.
5. If engine is deemed illegal competitor will be suspended for one year and engine will be confiscated by SSCRA. Engine will be confiscated by SSCRA.
6. Failure to comply with the demand of the SSCRA Official to seize crate / open motor for inspection will result in suspension of all privileges for competitor(s) of seriated motor(s) to compete at any SSCRA events for up to one year.

I understand and agree to the terms and conditions as outlined above.

Crate / Open Engine Owner Signature

Crate / Open Engine Driver Signature

Witness Name & Signature

Witness Name & Signature

Date

Date

RELEASE OF LIABILITY, WAIVER OF CLAIMS, ASSUMPTION OF RISKS AND INDEMNITY AGREEMENT
BY SIGNING THIS DOCUMENT YOU WILL WAIVE CERTAIN LEGAL RIGHTS, INCLUDING THE RIGHT TO SUE.

PLEASE READ CAREFULLY!

Description and location of scheduled event(s) (the "**EVENT**") Date release signed

In full or partial consideration for allowing me to participate in all related events and activities of the **EVENT**, I hereby warrant and agree that:

1. I am familiar with and accept that there is the risk of serious injury and death in participation, whether as a competitor, student, official or worker, in all forms of motor sport and in particular in being allowed to enter, for any reason, any restricted area; and
2. I have satisfied myself and believe that I am physically, emotionally and mentally able to participate in this **EVENT**, and that my protective clothing, gear and equipment is fit and appropriate for my role as a participant in this **EVENT**; and
3. I understand that all applicable rules for participation must be followed, regardless of my role, and that at all times during the **EVENT** the sole responsibility for my personal safety remains with me; and
4. I will immediately remove myself from participation, and notify the nearest official, if at any time I sense or observe any unusual hazard or unsafe condition or if I feel that I have experienced any deterioration in my physical, emotional or mental fitness, or that of my protective clothing, gear or equipment, for continued safe participation in the **EVENT**.

I UNDERSTAND AND AGREE, ON BEHALF OF MYSELF, MY HEIRS, ASSIGNS, PERSONAL REPRESENTATIVES AND NEXT OF KIN THAT MY EXECUTION OF THIS DOCUMENT CONSTITUTES:

1. AN UNQUALIFIED ASSUMPTION BY ME OF ALL RISKS associated with my participation in the **EVENT** even if arising from the negligence or gross negligence, including any compounding or aggravation of injuries caused by negligent rescue operations or procedures, of the Releasees, as that term is defined below, and any persons associated therewith or otherwise participating in the **EVENT** in any capacity; and
2. A FULL AND FINAL RELEASE AND WAIVER OF LIABILITY AND ALL CLAIMS that I have, or may in the future have, against any person(s), entities or organization(s) associated in any way with the **EVENT** including the track owners and lessees, promoters, sanctioning bodies, racing associations, or any subdivision thereof, track operators, sponsors, advertisers, car owners and other participants, rescue personnel, event inspectors, underwriters, consultants and others who give recommendations, directions or instructions or engage in risk evaluation and loss control activities, regarding the **EVENT** or event premises, or any one or more of them and their respective directors, officers, employees, guides, contractors, agents and representatives (all of whom are collectively referred to as "the Releasees") from any and all liability for any loss, damage, injury or expense that I may suffer as a result of my use of or my presence at the event facilities or my participation in any part of, or my presence in any capacity at, the **EVENT**, due to any cause whatsoever, INCLUDING NEGLIGENCE, GROSS NEGLIGENCE, BREACH OF CONTRACT, OR BREACH OF ANY STATUTORY OR OTHER DUTY OF CARE, INCLUDING ANY DUTY OF CARE OWED UNDER THE RELEVANT OCCUPIERS LIABILITY ACT ON THE PART OF THE RELEASEES.
3. AN AGREEMENT NOT TO SUE THE RELEASEES for any loss, injury, costs or damages of any form or type, howsoever caused or arising, and whether directly or indirectly from my participation in any aspect(s) of the **EVENT**; and
4. AN AGREEMENT TO INDEMNIFY, and to SAVE and HOLD HARMLESS the RELEASEES, and each of them, from any litigation expense, legal fees, liability, damage, award or cost, of any form or type whatsoever, they may incur due to any claim made against them or any one of them by me or on my behalf, or that of my estate, whether the claim is based on the negligence or the gross negligence of the Releasees or otherwise as stated above.
5. AN AGREEMENT that this document be governed by the laws, and in the courts, of the Province in which the **EVENT** occurs.

I HAVE READ AND UNDERSTAND THIS AGREEMENT AND I AM AWARE THAT BY SIGNING THIS AGREEMENT I AM WAIVING CERTAIN SUBSTANTIAL LEGAL RIGHTS WHICH I AND MY HEIRS, NEXT OF KIN, EXECUTORS, ADMINISTRATORS AND ASSIGNS MAY HAVE AGAINST THE RELEASEES.

I SIGN THIS DOCUMENT VOLUNTARILY AND WITHOUT INDUCEMENT

Signature of Participant

Printed Name of Participant

Signature of Witness



**MINOR PARTICIPANT
ASSUMPTION AND ACKNOWLEDGMENT OF RISK**

Description and location of scheduled event(s) (the "EVENT")

Date release signed

I UNDERSTAND AND AGREE, on behalf of myself, my heirs, assigns, personal representatives and next of kin, that my participation in the **EVENT** is not permitted without my execution of this document. I hereby warrant and agree that:

1. I know that there are significant risks including the risk of serious injury or death associated with participation, whether as a competitor, student, official or worker in all forms of motor sport and in particular in being allowed to enter, for any reason, any restricted area; and
2. I acknowledge and accept these risks and all other risks associated with participation in this **EVENT** even if arising from negligence or gross negligence, including any worsening of injuries caused by negligent rescue operations or procedures, of the **EVENT** organizer, the **EVENT** venue(s) and of any and all persons associated therewith or participating therein; and
3. I understand that all applicable rules for participation must be followed, regardless of my role, and that at all times **THE SOLE RESPONSIBILITY FOR MY PERSONAL SAFETY REMAINS WITH ME;**
4. I will immediately remove myself from participation in the **EVENT** and notify the nearest official, if at any time I sense any unusual hazard or unsafe condition or if I feel that I have experienced any deterioration in my physical, emotional or mental fitness, or that of my protective clothing, gear or equipment, for continued safe participation in the **EVENT**; and
5. I am _____ years of age.

I HAVE READ AND UNDERSTAND THIS DOCUMENT AND I AM AWARE THAT BY SIGNING THIS ASSUMPTION AND ACKNOWLEDGMENT OF RISK I AND/OR MY PARENTS/GUARDIANS MAY SURRENDER CERTAIN LEGAL RIGHTS.

I SIGN THIS DOCUMENT VOLUNTARILY AND WITHOUT INDUCEMENT

Signature of Minor Participant

Printed name of Minor Participant

Signature of Witness

** MUST BE ACCOMPANIED BY PARENTAL WAIVER.

RELEASE OF LIABILITY, WAIVER OF CLAIMS, ASSUMPTION OF RISKS AND INDEMNITY AGREEMENT BY SIGNING THIS DOCUMENT YOU WILL WAIVE CERTAIN LEGAL RIGHTS, INCLUDING THE RIGHT TO SUE.

PLEASE READ CAREFULLY!

Description and location of scheduled event(s) (the "EVENT")

Date release signed

In full or partial consideration for allowing my minor child/ward to participate in all related activities of the *EVENT*, I hereby warrant and agree that:

1. I am the parent/guardian having full legal responsibility for decisions regarding my minor child/ward, *namely* _____; and
2. I am familiar with and accept, on behalf of myself and my minor child/ward, that there is the risk of serious injury and death in participation, whether as a competitor, student, official or worker, in all forms of motor sport and in particular in being allowed to enter, for any reason, any restricted area; and
3. I have satisfied myself and believe that my minor child/ward is physically, emotionally and mentally able to participate in this *EVENT*, and that his/her protective clothing, gear and equipment is fit and appropriate for his/her use in this *EVENT*; and
4. I understand, and will instruct my minor child/ward, that regardless of his/her role, all applicable rules for participation must be followed and that at all times the sole responsibility for personal safety remains with my minor child/ward; and
5. I will immediately remove my minor child/ward from participation, and notify the nearest official, if at any time I sense or observe any unusual hazard or unsafe condition or if I feel that my minor child/ward has experienced any deterioration in his/her physical, emotional or mental fitness, or that of his/her protective clothing, gear or equipment, for continued safe participation in the *EVENT*.

I UNDERSTAND AND AGREE, ON BEHALF OF MY MINOR CHILD/WARD, HIS/HER HEIRS, ASSIGNS, PERSONAL REPRESENTATIVES AND NEXT OF KIN, MYSELF, MY HEIRS, ASSIGNS, PERSONAL REPRESENTATIVES AND NEXT OF KIN THAT MY EXECUTION OF THIS DOCUMENT CONSTITUTES:

1. AN UNQUALIFIED ASSUMPTION OF ALL RISKS associated with participation in the *EVENT* by my minor child/ward even if arising from negligence or gross negligence, including any compounding or aggravation of injuries caused by negligent rescue operations or procedures, of the event organizer, the event venue(s) and of any persons associated therewith or participating therein; and
2. A FULL AND FINAL RELEASE AND WAIVER OF LIABILITY AND ALL CLAIMS that I have or may in the future have against any person(s), entities, or organization(s) associated in any way with the *EVENT* including the track owners and lessees, promoters, sanctioning bodies, racing associations, or any subdivision thereof, track operators, sponsors, advertisers, vehicle owners and other participants, rescue personnel, event inspectors, underwriters, consultants, and others who give recommendations, directions or instructions, or engage in risk evaluation and loss control activities, regarding the *EVENT* or event premises, or any one or more of them, and their respective directors, officers, employees, contractors, agents and representatives (all of whom are collectively referred to as "the Releasees") from any and all liability for any loss, damage, injury or expense that my minor child/ward may suffer, or that his/her next of kin may suffer as a result of his/her use of or presence at the event facilities or my child's/ward's participation in any part of, or presence at, the *EVENT*, due to any cause whatsoever, INCLUDING NEGLIGENCE, GROSS NEGLIGENCE, BREACH OF CONTRACT, OR BREACH OF ANY STATUTORY OR OTHER DUTY OF CARE, INCLUDING ANY DUTY OF CARE OWED UNDER THE RELEVANT *OCCUPIERS LIABILITY ACT* ON THE PART OF THE RELEASEES; and
3. AN AGREEMENT NOT TO SUE THE RELEASEES for any loss, injury, costs or damages of any form or type, howsoever caused or arising, and whether directly or indirectly from the participation of my minor child/ward in any aspect of the *EVENT*; and
4. AN AGREEMENT TO INDEMNIFY, and to SAVE and HOLD HARMLESS the RELEASEES, and each of them, from any litigation expense, legal fees, liability, damage, award or cost, of any form or type whatsoever, they may incur due to any claim made against them or any one of them whether the claim is based on the negligence or the gross negligence of the Releasees or otherwise.
5. AN AGREEMENT that this document be governed by the laws of the Province in which the *EVENT* occurs.

I HAVE READ AND UNDERSTAND THIS AGREEMENT AND I AM AWARE THAT BY SIGNING THIS AGREEMENT I AM WAIVING CERTAIN SUBSTANTIAL LEGAL RIGHTS WHICH MY MINOR CHILD/WARD, HIS/HER HEIRS, NEXT OF KIN, EXECUTORS, ADMINISTRATORS AND ASSIGNS AND I AND/OR MY MINOR CHILD/WARD MAY HAVE AGAINST THE RELEASEES.

I SIGN THIS DOCUMENT VOLUNTARILY AND WITHOUT INDUCEMENT

Signature of Parent/Guardian(s)

Printed name of Parent/Guardian(s)

Signature of Witness